



# Installation Guide

4GE xPON ONU  
SG04



Scan the QR code or visit **[www.tendacn.com](http://www.tendacn.com)** for installation videos, technical specifications and more information.

You can see the product name and model on the product label. The label can be found on the bottom of the device.

# Package Contents

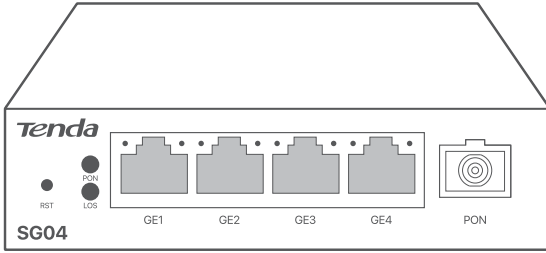

ONU × 1

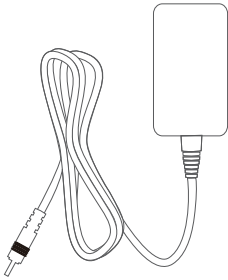

Power adapter × 1



Quick installation guide × 1

# 1. Install the ONU

---

## ■ Preparations

- Desktop mounting: ESD bracelet or gloves
- Wall mounting: ESD bracelet or gloves, ladder, screwdriver, marker, hammer drill, rubber hammer, spirit level, 2 screws (self-prepared, thread diameter: 3 mm, length: 14 mm, head diameter: 5.2 mm), 2 plastic anchors (self-prepared, height: 6.6 mm, inner diameter: 2.4 mm, length: 26.4 mm)

## ■ Desktop Mounting

Horizontally place the ONU right-side up on a big enough, clean, stable and flat desktop.

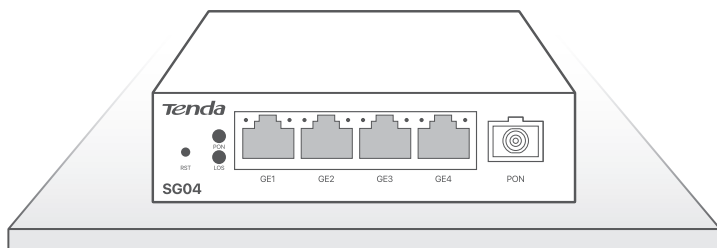

## ■ Wall Mounting

---

### NOTE

- The ONU can only be installed on non-flammable walls, such as a concrete wall.
- Do **NOT** install the ONU with air vents facing downward. Otherwise, there will be potential safety hazards.

- 
- 1 Mark your wall for the wall-mounting slots on the bottom of the ONU (distance between two holes: 80 mm) and drill two holes (diameter: 6 mm) horizontally.
  - 2 Hammer plastic anchors into the holes.
  - 3 Insert screws into the plastic anchors, leaving a gap (at least 2.5 mm) between the screw heads and plastic anchors.
  - 4 Place the ONU on the screws and slide it down until it locks into place.

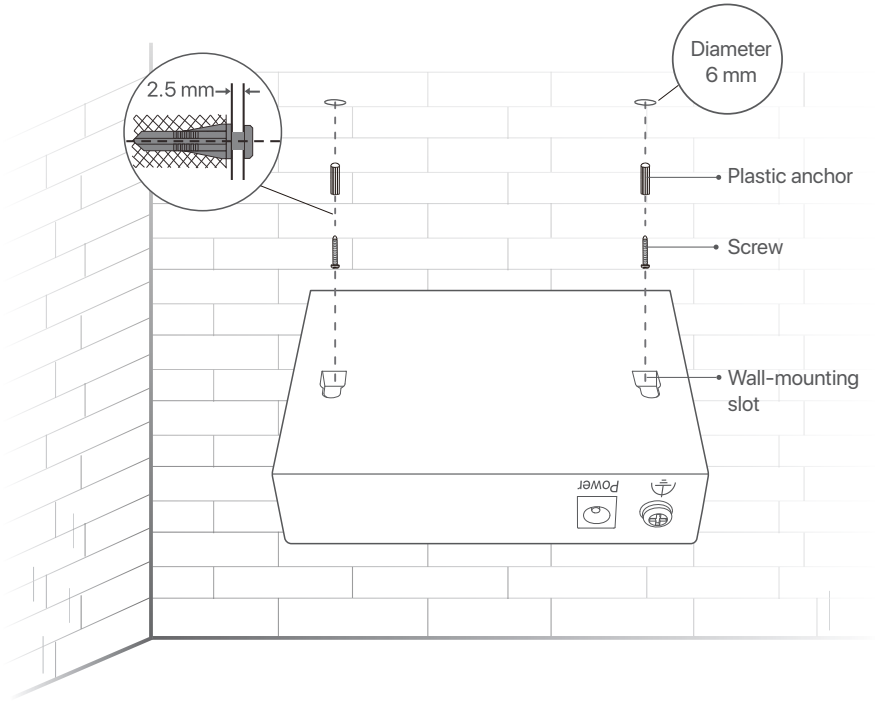

## 2. Connect the ONU



### Caution, laser

Never look at the transmit laser while the power is on. DO NOT look directly at the **PON** port and the fiber cable ends when they are powered on, to prevent any harm to your eyes.

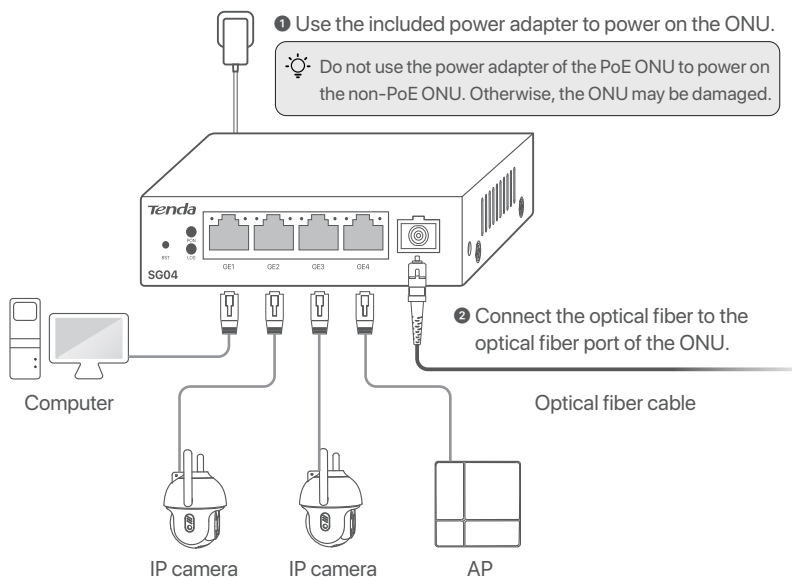

③ Use Ethernet cables to connect LAN devices (such as routers, APs, IP cameras, computers, and so on) to the Ethernet port of the ONU as required.

\*The ONU does not support PoE power supply. Power on the devices connected to the ONU separately.

When the **PON** indicator lights solid on (successful registration) and the **LOS** indicator is off (normal receive optical power), the device connected to the ONU can be configured network settings as required.

# 3. Connect Clients to the Internet

## ■ For Wi-Fi-enabled devices:

- 1 Use Ethernet cables to connect such wireless network devices as wireless routers and APs to any Ethernet port of the ONU.
- 2 (Optional) Configure the wireless router to access the internet.
- 3 Connect the wireless network of the wireless network devices for internet access. If the dual-band function is available, connect to any wireless network to access the internet. It is recommended to connect to 5GHz wireless network.

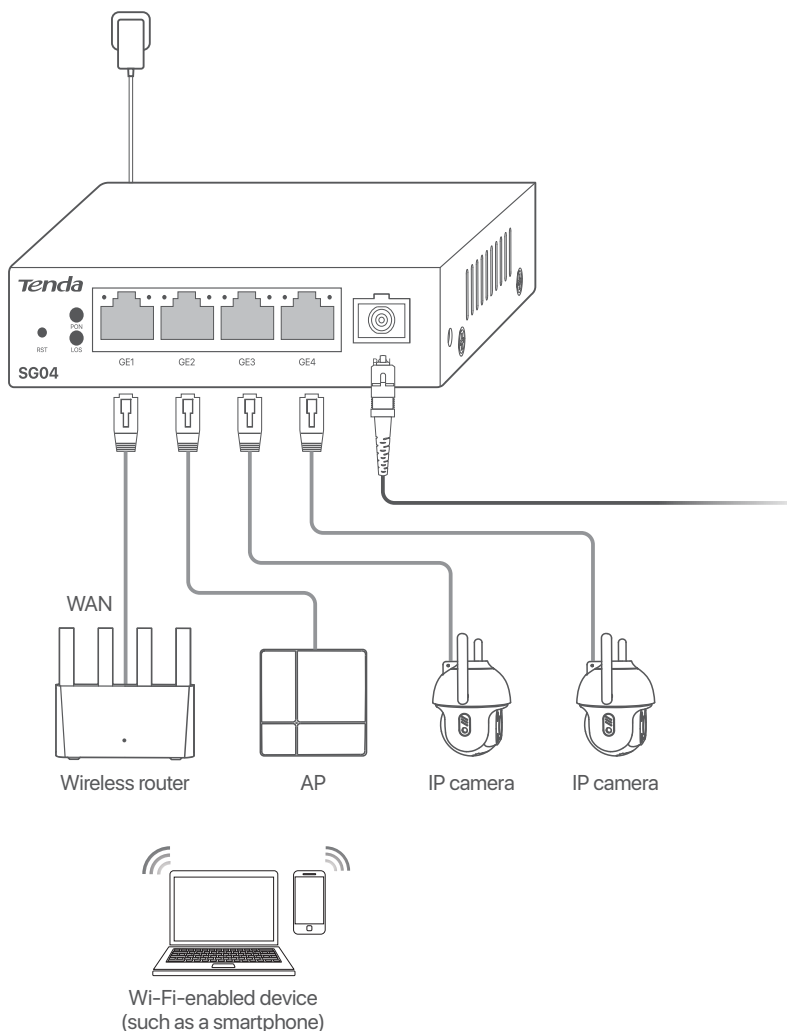

## ■ For wired devices:

Use Ethernet cables to connect such devices as computers to any Ethernet port of the ONU, and then configure devices to access the internet (such as dial-up internet access).

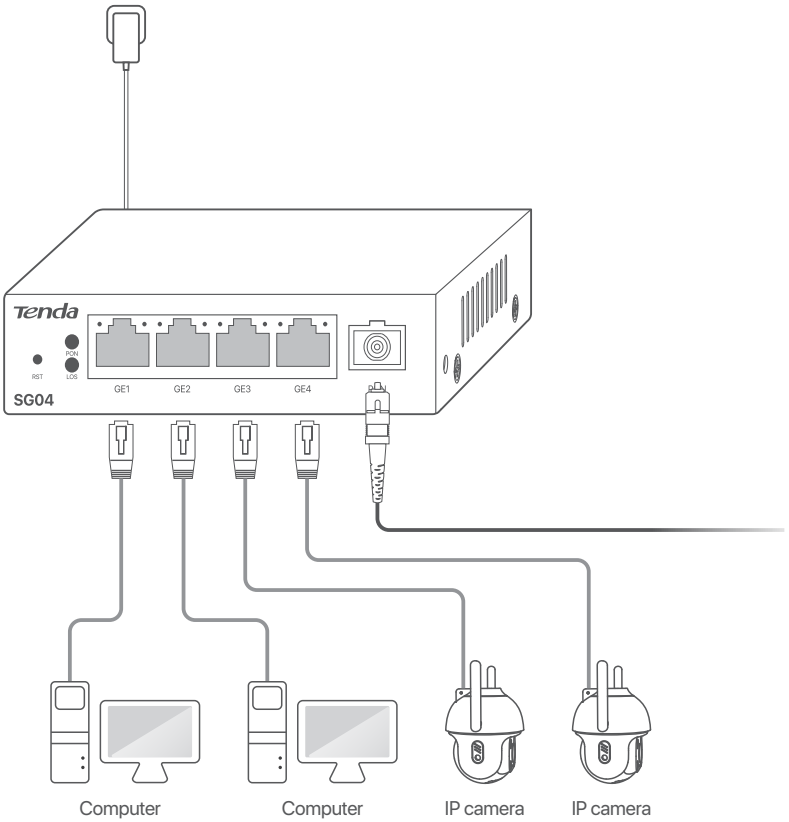

## 4. Log in to the Web UI

---

- 1 Use an Ethernet cable to connect the computer to any Ethernet port of the ONU.
- 2 Set the IP address of the computer to the IP address within the same network segment as the ONU.  
For example, if the IP address of the ONU is 192.168.1.1, you can set the IP address of your computer to 192.168.1.X (X ranges from 2 to 254 and is unused) and subnet mask to 255.255.255.0.
- 3 Start a web browser (such as Chrome) on your computer, and enter the management IP address (**192.168.1.1** by default) to log in to the web UI of the ONU.



- 4 Enter the user name and password (both are **admin**), and click **Login**.

A screenshot of the Tenda web UI login page. At the top center is the "Tenda" logo in orange. Below the logo are two input fields: "User Name:" and "Password:". Underneath these fields are two orange buttons: "Login" and "Reset". At the bottom left, there is a "Language Select:" dropdown menu currently set to "English".

Clear the user name and password entered in the current input box



# Specifications

Item		Specification
Port	PON port	SC/UPC or SC/APC
	Ethernet port	4 × 10/100/1000 Mbps auto-negotiation RJ45 ports
Operating/Storage environment	Operating environment	Temperature: -20°C-55°C (-4°F-131°F) Humidity: (10% - 95%) RH, non-condensing
	Storage environment	Temperature: -40°C-70°C (-40°F-158°F) Humidity: (5% - 90%) RH, non-condensing
Dimensions (Length × width × height)	100 mm × 100 mm × 26 mm	

# Indicators/Ports/Button

## ■ Front Panel

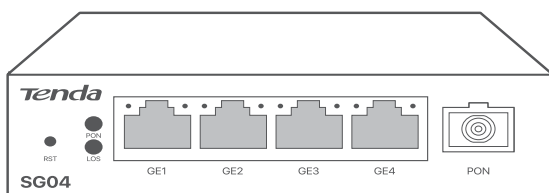

## Indicator Status Description

Indicator	Description
PON(Green)	<b>Solid on:</b> The ONU is registered successfully. <b>Blinking:</b> The ONU is registering. <b>Off:</b> The optical signal is weak or there is no optical signal.
LOS(Red)	<b>Blinking:</b> The received optical power is lower than the optical receiver sensitivity, or the optical fiber is not inserted. <b>Off:</b> The received optical power is at a proper value.
Ethernet port status	The green indicator means the port negotiation rate is 1000 Mbps. The orange indicator means the port negotiation rate is 10/100 Mbps. <b>Solid on:</b> The Ethernet port is connected. <b>Blinking:</b> The Ethernet port is transmitting data. <b>Off:</b> The Ethernet port is disconnected.

## Ports and Button Description

Port/Button	Description
RST	Reset button. For the reset method, refer to <b>Q3</b> in <b>FAQ</b> .
GE1-GE4	10/100/1000 Mbps auto-negotiation RJ45 port.
PON	SC/UPC or SC/APC optical fiber port.

## ■ Back Panel

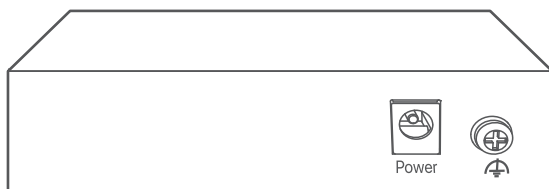

## Jack and Terminal

Jack/Terminal	Description
	Power jack. Connect the ONU to a power source using the included power adapter.
	GGrounding terminal. Use a grounding cable (self-prepared) to connect the grounding terminal of the ONU to the earth or the grounding terminal of the building to prevent damage to the ONU caused by static electricity or lightning strikes.

# FAQ

## **Q1. I cannot log in to the web UI of the ONU by visiting 192.168.1.1. What should I do?**

Try the following solutions:

- Ensure that the ONU is powered on properly.
- Ensure that your computer is connected to the ONU properly.
- Ensure that the IP address of the computer is set to the IP address within the same network segment as the ONU.
- Ensure that there is no device in the network has the same IP address as the ONU.
- Clear the cache of your web browser or try again with another web browser.

If the problem still persists, refer to **Q3** to reset the ONU and try again.

## **Q2. After the Ethernet port of the ONU is connected to the device, the indicator of the corresponding port does not light up. What should I do?**

- Ensure that the power adapter is connected to the ONU and the power socket properly.
- Ensure that the connected device is powered on and working properly.
- Ensure that the powered device is connected to the ONU properly with CAT5e or above Ethernet cable.

## **Q3. How to reset the ONU?**

- For the ONU with the preset configurations: After the ONU completes startup, press the reset button (**RST**) with a needle-like object for 8 to 20 seconds, and the ONU is restored to the preset configurations. Press the reset button (**RST**) with a needle-like object for more than 20 seconds, and the ONU is restored to the factory settings.
- For the ONU without the preset configurations: After the ONU completes startup, press the reset button (**RST**) with a needle-like object for more than 8 seconds, and the ONU is restored to the factory settings.

## **Q4. The PON indicator keeps blinking. What should I do?**

It indicates that the ONU failed to register with the OLT. Try the following solutions:

- **Check the optical fiber connection:** Use an optical power meter to measure the 1490 nm signal strength to ensure that the optical power value is within the normal range (-8 dBm to -28 dBm). Optical power that is too low or too high will cause ONU registration failure.

- **Check the ONU and OLT configurations:** Check the OLT configuration and confirm whether the ONU is required to configure authentication parameters, such as LOID. Check the list of unauthorized ONUs. If the unauthorized ONU is found, authorize it normally and make the ONU online.

#### **Q5. The LOS indicator keeps blinking. What should I do?**

It indicates that the ONU cannot detect the optical signal. Try the following solutions:

- **Check the optical fiber power:** Use an optical power meter to measure the 1490 nm signal strength to ensure that an optical power value exists. Ensure that the received optical power is at a proper value.
- **Check the status of the OLT optical module:** Ensure that the optical module is installed properly without damage or loose cable/optical module. Or replace another optical module and try again.

# Safety Precautions

Before operating, read the operation instructions and precautions to be taken, and follow them to prevent accidents. The warning and danger items in other documents do not cover all the safety precautions that must be followed. They are only supplementary information, and the installation and maintenance personnel need to understand the basic safety precautions to be taken.

- This device can be used indoors and outdoors.
- For wall mounting, the device is only suitable for mounting at heights  $\leq 2\text{m}$ .
- For desktop mounting, the device must be horizontally mounted for safe use.
- This device should be installed by trained and qualified personnel in compliance with local and national electrical regulations.
- During installation, do not wear conductive items (such as a watch, or hand chain).
- During installation, the device should remain powered off.
- Clean only with dry cloth.
- Keep the operating environment clean. Remove dust from the device regularly. Cut power before cleaning.
- Do not block any ventilation openings.
- Do not remove the cover of the optical fiber before connecting the optical fiber to avoid contamination.
- Do not bend the optical fiber at will. The optical fiber must be bent strictly in accordance with the optical cable construction requirements to ensure normal transmission of optical signals.
- Do not use the power adapter if its plug or cord is damaged.
- Do not place heavy objects on top of the device.
- Please use the included power adapter.
- The mains plug is used as the disconnect device and shall remain readily operable.
- The power socket shall be installed near the device and easily accessible.
- Ensure proper grounding before device operation. Refer to the **Lightning Protection Guide** on the official website for guidance.
- Keep the device away from water, fire, high electric field, high magnetic field, and inflammable and explosive items.
- Unplug this device and disconnect all cables when the device is unused for long periods.
- If such phenomena as smoke, abnormal sound or smell appear when you use the device, immediately stop using it and disconnect its power supply, unplug all connected cables, and contact the after-sales service personnel.
- Disassembling or modifying the device or its accessories without authorization voids the warranty, and might cause safety hazards.
- Refer all servicing to qualified service personnel.
- Disconnect the power source during servicing.

For the latest safety precautions, see **Safety and Regulatory Information** on [www.tendacn.com](http://www.tendacn.com).



## CE Mark Warning

This is a Class A product.

Warning: Operation of this equipment in a residential environment could cause radio interference. In which case the user may be required to take adequate measures.

**NOTE:** (1) The manufacturer is not responsible for any radio or TV interference caused by unauthorized modifications to this equipment. (2) To avoid unnecessary radiation interference, it is recommended to use a shielded RJ45 cable.

### Declaration of Conformity

Hereby, SHENZHEN TENDA TECHNOLOGY CO., LTD. declares that the device (ONU) is in compliance with Directives 2014/35/EU and 2014/30/EU.

The full text of the EU Declaration of Conformity is available at the following internet address:

<https://www.tendacn.com/download/list-9.html>



## RECYCLING

This product bears the selective sorting symbol for Waste Electrical and Electronic Equipment (WEEE). This means that this product must be handled pursuant to European directive 2012/19/EU in order to be recycled or dismantled to minimize its impact on the environment.

User has the choice to give his product to a competent recycling organization or to the retailer when he buys a new electrical or electronic equipment.

## Technical Support

Shenzhen Tenda Technology Co., Ltd.

Floor 6-8, Tower E3, No.1001, Zhongshanyuan Road, Nanshan District, Shenzhen, China.  
518052

Website: [www.tendacn.com](http://www.tendacn.com)

E-mail: [support@tenda.com.cn](mailto:support@tenda.com.cn)

**Copyright © 2024 Shenzhen Tenda Technology Co., Ltd. All rights reserved.**

Tenda is a registered trademark legally held by Shenzhen Tenda Technology Co., Ltd. Other brand and product names mentioned herein are trademarks or registered trademarks of their respective holders. Specifications are subject to change without notice.

V1.0 Keep for future reference.