

*Tenda*



All for better networking.

**TM5**

**2.5G GPON OLT SFP C++ SC Optical Transceiver**

[www.tenda.cn.com](http://www.tenda.cn.com)

## Product Features

- SC BIDI SFP Single Mode Transceiver
  - 1490nm Continuous Mode 2.488 Gbps DFB Transmitter
  - 1310nm Burst Mode 1.244 Gbps APD-TIA Receiver)
- Single +3.3 Power Supply, Hot-pluggable
- LVTTTL receiver Fast Burst Packet Detect indication
- Burst mode received signal strength indication (RSSI) function
- Complies with Telcordia (Bellcore) GR-468-CORE
- Class I laser safety standard IEC-60825 compliant
- Compliant with SFP MSA and SFF-8472
- Complies with ITU-T G.984.2 Class C++



## Product Applications

- GPON OLT For P2MP Application

## General

The TM5 transceiver with supports data rate of typical 2.488 Gbps for GPON OLT application up to 20km transmission distance, it's designed meeting with ITU-T G.984.2 Class B+/ C+/ C++ specifications. SC receptacle is for optical interface.

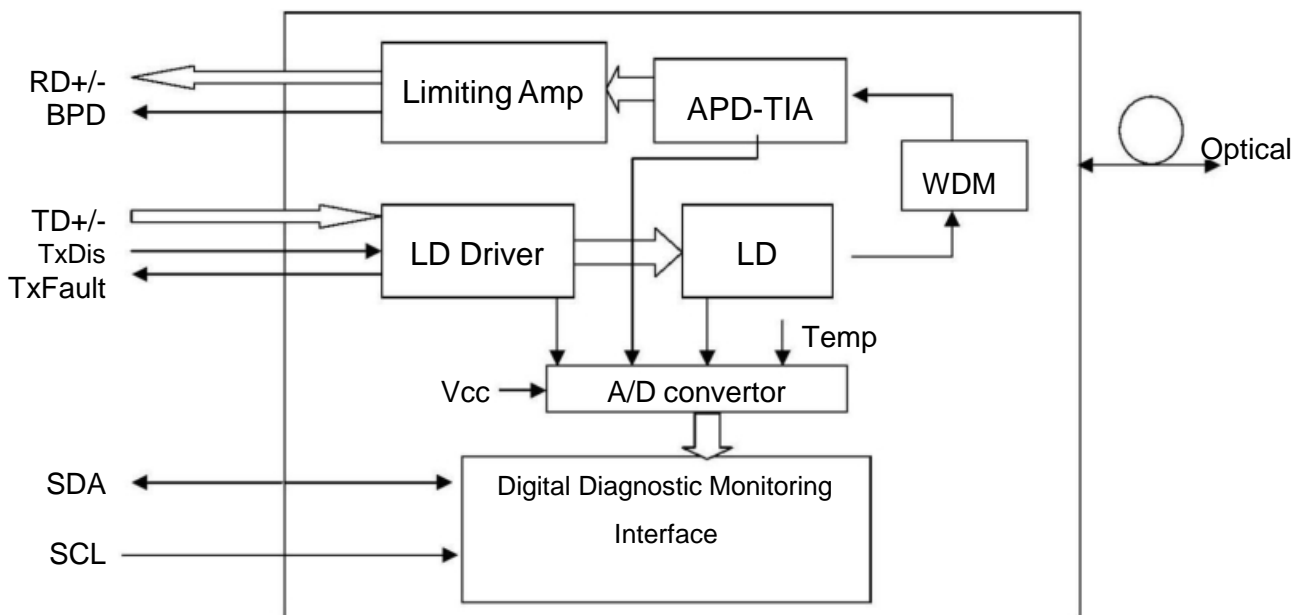

Fig 1 Transceiver Block Diagram

The module provides digital diagnostic information of its operating conditions and status, including transmitting power, laser bias, receiver input optical power, module temperature, and supply voltage. Calibration and alarm/warning threshold data are written and stored in internal memory (EEPROM). The memory map is compatible with SFF-8472, as shown in Fig. 2. The diagnostic data are raw A/D values and must be converted to real world units using calibration constants stored in EEPROM locations 56 – 95 in A2h.

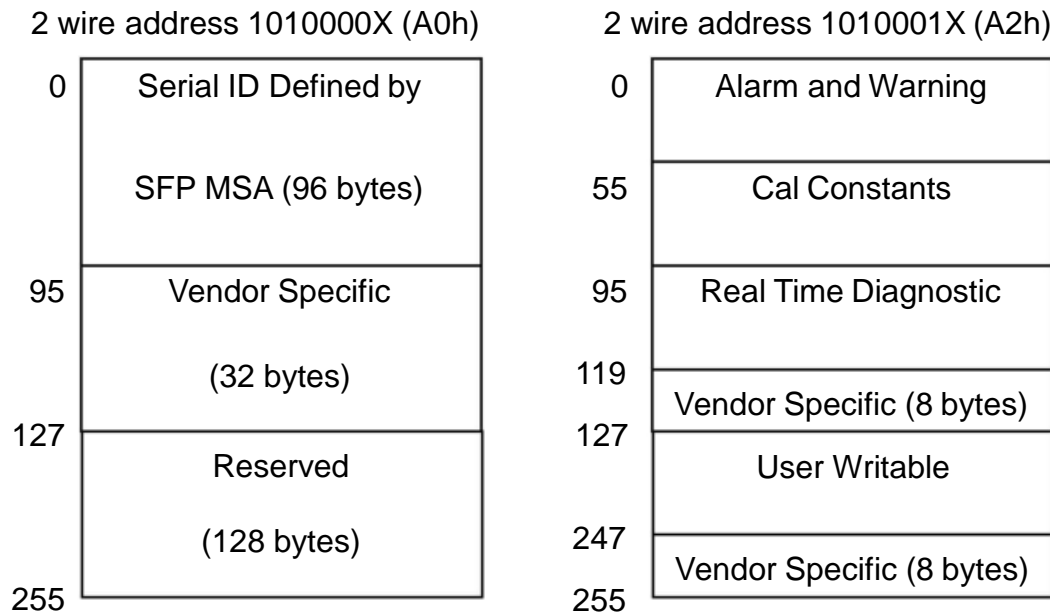

Fig 2 EEPROM Information

## Performance Specifications

Absolute Maximum Ratings						
Parameter	Symbol	Min.	Max.	Unit	Note	
Storage Temperature	Tst	-40	+85	°C		
Operating Case Temperature	Tc	0	70	°C		
Input Voltage	-	GND	Vcc	V		
Power Supply Voltage	Vcc-Vee	-0.5	+3.6	V		
Recommended Operating Conditions						
Parameter	Symbol	Min.	Typical	Max.	Unit	Note
Power Supply Voltage	Vcc	3.135	3.3	3.465	V	
Operating Case Temperature	Tc	0	-	70	°C	
Data Rate	TX	-	2.488	-	Gbps	
	RX	-	1.244	-		

Total Supply Current	-	-	-	400	mA	
Damage Threshold For Receiver	-	-	-	4	dBm	

## Optical Specification

### Transmitter

Parameter	Symbol	Min.	Typ.	Max.	Unit	Note
Optical Central Wavelength		1480	1490	1500	nm	-
Spectral Width (-20dB)		-	-	1	nm	-
Side Mode Suppression Ratio	SMSR	30	-	-	dB	-
Average Optical Output Power	Po	+2.5	+4	+6	dBm	B+
		+3.5	+5	+7		C+
		+5	+7	+10		C++
Extinction Ratio	Er	8.2	-	-	dB	-
Rise/Fall Time	Tr/Tf	-	-	150	ps	-
Transmitter Total Jitter	Jp-p	-	-	0.1	UI	
Transmitter Reflectance	RFL	-	-	-12	dB	
Average Launched Power of Off Transmitter	Poff	-	-	-39	dBm	-
Differential Input Voltage	V <sub>IN-DIF</sub>	300	-	1600	mV	-
Tx Disable Input Voltage-Low	V <sub>IL</sub> V <sub>IH</sub>	0	-	0.8	V	-
Tx Disable Input Voltage-High		2.0	-	V <sub>CC</sub>	V	-
Output Eye	Compliant with ITU-T G.984.2					

### Receiver

Parameter	Symbol	Min.	Typ.	Max.	Unit	Note
Operate Wavelength	-	1260	1310	1360	nm	-
Sensitivity	Pr	-	-	-28	dBm	B+
		-	-	-30		C+/C++
Saturation	Ps	-8	-	-	dBm	B+
		-10	-	-		C+/C++
LOS assert Level	-	-45	-	-	dBm	

LOS De-Assert Level	-	-	-	-30	dBm	-
LOS Hysteresis	-	0.5	-	5	dB	-
Receiver Optical Reflectance	-	-	-	-12	dB	-
Data Output Low	V <sub>ol</sub>	-2	-	-1.58	V	-
Data Output High	V <sub>oh</sub>	-1.1	-	-0.74	V	-
LOS Output Voltage-Low	VSD-L	0	-	0.8	V	-
LOS Output Voltage-High	VSD-H	2.0	-	V <sub>cc</sub>	V	-

Note:

1. Minimum Sensitivity and saturation levels for an NRZ 223-1 PRBS. BER≤10<sup>-10</sup>, 1.244Gpbs, ER=9dB

## EEPROM Information

### EEPROM Serial ID Memory Contents (A0h)

Addr. (decimal)	Field Size (Bytes)	Name of Field	Content (Hex)	Content (Decimal)	Description
0	1	Identifier	03	3	SFP
1	1	Ext. Identifier	04	4	MOD4
2	1	Connector	01	1	SC
3-10	8	Transceiver	00 00 00 80 00 00 00 00	00 00 00 128 00 00 00 00	
11	1	Encoding	03	3	NRZ
12	1	BR, nominal	19	25	2.488Gbps
13	1	Reserved	00	0	-
14	1	Length (9um)-km	14	20	20km
15	1	Length(9um)	C8	200	20km
16	1	Length (50um)	00	0	-
17	1	Length (62.5um)	00	0	-
18	1	Length (copper)	00	0	-
19	1	Reserved	00		-
20-35	16	Vendor name			
36	1	Reserved	00	0	-
37-39	3	Vendor OUI	00 00 00	0 0 0	-
40-55	16	Vendor PN			

56-59	4	Vendor rev	30 30 30 20	48 48 48 32	"000" (ASCII)
60-61	2	Wavelength	05 D2	05 210	1490
62	1	Reserved	00	0	-
63	1	CCBASE	-	-	Check sum of bytes 0 - 62
64	1	Reserved	00	0	
65	1	Options	1C	28	
66	1	BR, max	00	0	-
67	1	BR, min	00	0	-
68-83	1	Vendor SN	-	-	ASCII
84-91	6 8	Vendor date	-	-	Year (2 bytes), Month (2 bytes), Day (2 bytes)
92	1	DDM Type	60	96	Internal Calibrated
93	1	Enhanced Option	80	128	LOS, TX_FAULT and Alarm/warning flags implemented
94	1	SFF-8472 Compliance	02	2	SFF-8472 Rev 10.3
95	1	CC EXT	-	-	Check sum of bytes 64 - 94
96-255	160	Vendor spec			

### Alarm and Warning Thresholds (Serial ID A2H)

Parameter (Unit)	C Temp (°C)	Voltage (V)	Bias (mA)	TX Power (dBm)			RX Power (dBm)		
High Alarm	100	3.6	90	+5	+8	+8	-8	-10	-10
Low Alarm	-10	3	1	+1.5	+3	+4	-28	-30	-30
High Warning	95	3.5	70	+4.5	+7.5	+7.5	-9	-11	-11
Low Warning	0	3.1	2	+2	+4	+5	-27	-29	-29

### Digital Diagnostic Monitor Accuracy

Parameter	Unit	Accuracy	Range	Calibration
Tx Optical Power	dB	±3	Po: -Pomin~Pomax dBm, Recommended operation conditions	External/Internal
Rx Optical Power	dB	±3	Pi: Ps~Pr dBm, Recommended operation conditions	External/Internal
Bias Current	%	±10	Id: 1-100mA, Recommended operating conditions	External/Internal
Power Supply Voltage	%	±3	Recommended operating conditions	External/Internal
Internal Temperature	°C	±3	Recommended operating conditions	External/Internal

## PIN Diagram

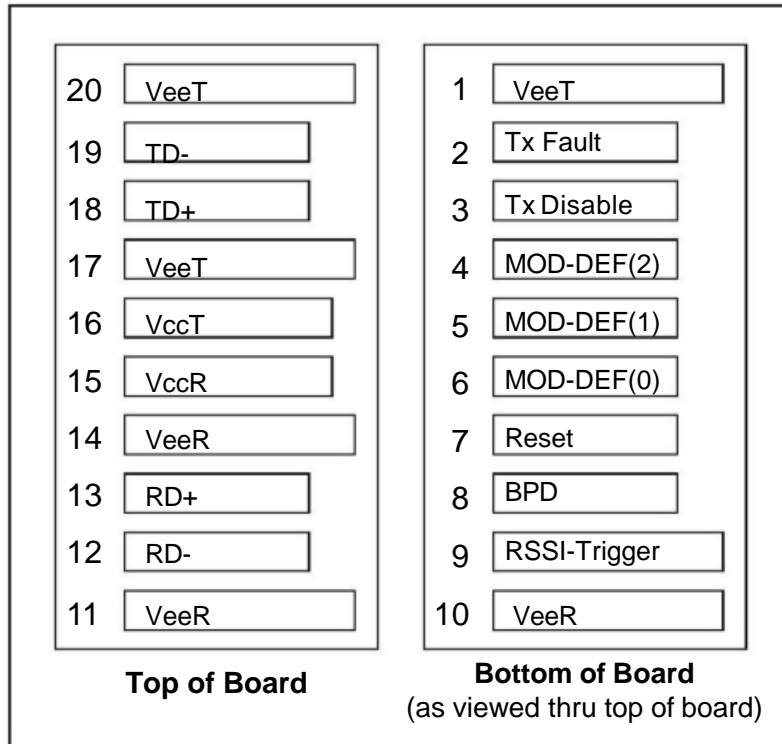

## PIN Description

Pin No.	Name	Function	Plug Seq.	Notes
1	VeeT	Transmitter Ground	1	
2	Tx Fault	Transmitter Fault Indication	3	Note 1
3	Tx Disable	Transmitter Disable	3	Note 2
4	MOD-DEF2	Module Definition 2	3	Note 3
5	MOD-DEF1	Module Definition 1	3	Note 3
6	MOD-DEF0	Module Definition 0	3	Note 3
7	Reset	Reset signal input	3	
8	BPD	Burst Power Detect (active HIGH)	3	Note 4
9	RSSI-Trigger	Receiver Signal Strength Indication	1	
10	VeeR	Receiver Ground	1	Note 5
11	VeeR	Receiver Ground	1	Note 5
12	RD-	Inv. Receiver Data Out	3	Note 6
13	RD+	Receiver Data Out	3	Note 6
14	VeeR	Receiver Ground	1	Note 5
15	VccR	Receiver Power Supply	2	Note 7, 3.3V 5%

16	VccT	Transmitter Power Supply	2	Note 7, 3.3V 5%
17	VeeT	Transmitter Ground	1	Note 5
18	TD+	Transmitter Data In	3	Note 8
19	TD-	Inv. Transmitter Data In	3	Note 8
20	VeeT	Transmitter Ground	1	Note 5

Notes:

1. TX Fault is an open collector/drain output, which should be pulled up with a 4.7K–10K $\Omega$  resistor on the host board. Pull up voltage between 2.0V and VccT, R+0.3V. When high, output indicates a laser fault of some kind. Low indicates normal operation. In the low state, the output will be pulled to < 0.8V.
2. TX disable is an input that is used to shut down the transmitter optical output. It is pulled up within the module with a 4.7–10 K $\Omega$  resistor. Its states are:
  - Low (0 – 0.8V): Transmitter on
  - (>0.8, < 2.0V): Undefined
  - High (2.0 – 3.465V): Transmitter Disabled
  - Open: Transmitter Disabled
3. Mod-Def 0,1,2. These are the module definition pins. They should be pulled up with a 4.7K – 10K $\Omega$  resistor on the host board. The pull-up voltage shall be VccT or VccR.
  - Mod-Def 0 is grounded by the module to indicate that the module is present
  - Mod-Def 1 is the clock line of two wire serial interface for serial ID
  - Mod-Def 2 is the data line of two wire serial interface for serial ID
4. BPD is pulled up internally with a 4.7K – 10K $\Omega$  resistor. Pull up voltage between 2.0V and VccT, R+0.3V. When LOW, this output indicates the received optical power is below the worst-case receiver sensitivity (as defined by the standard in use). HIGH indicates normal operation. In the low state, the output will be pulled to < 0.8V.
5. VeeR and VeeT may be internally connected within the SFP module.
6. RD-/+ : These are the differential receiver outputs. They are DC coupled 100 $\Omega$  differential lines which should be terminated with 100 $\Omega$  (differential) at the user SERDES.
7. VccR and VccT are the receiver and transmitter power supplies. They are defined as 3.3V 5% at the SFP connector pin. Maximum supply current is 450mA. Recommended host board power supply filtering is shown below. Inductors with DC resistance of less than 1 $\Omega$  should be used in order to maintain the required voltage at the SFP input pin with 3.3V supply voltage. When the recommended supply filtering network is used, hot plugging of the SFP transceiver module will result in an inrush current of no more than 30 mA greater than the steady state value. VccR and VccT may be internally connected within the SFP transceiver module.
8. TD-/+ : These are the differential transmitter inputs. They are AC-coupled, differential lines with 100 $\Omega$  differential termination inside the module. The AC coupling is done inside the module and is thus not required on the host board.



## Package Diagram

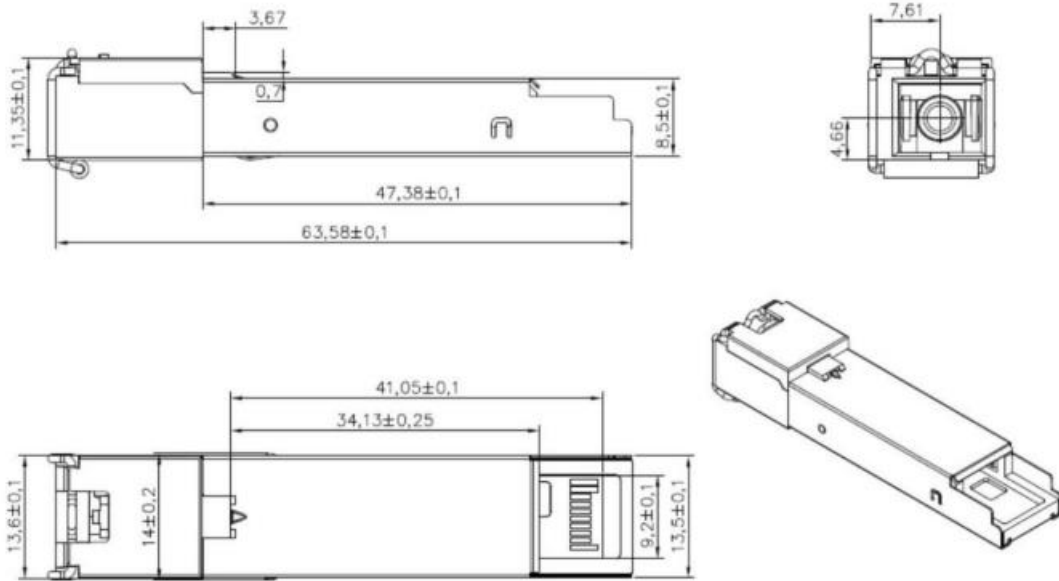

## Recommended Circuit

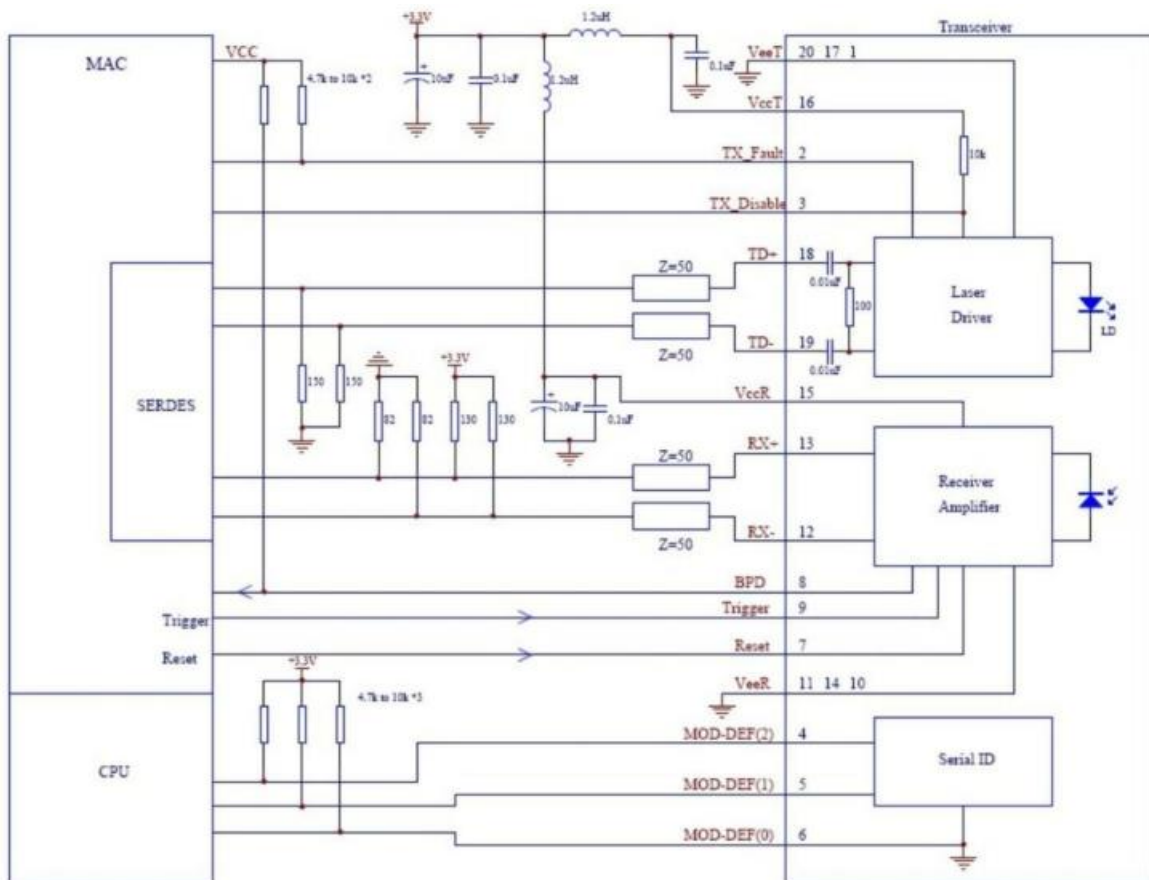

## Timing Parameter Definition

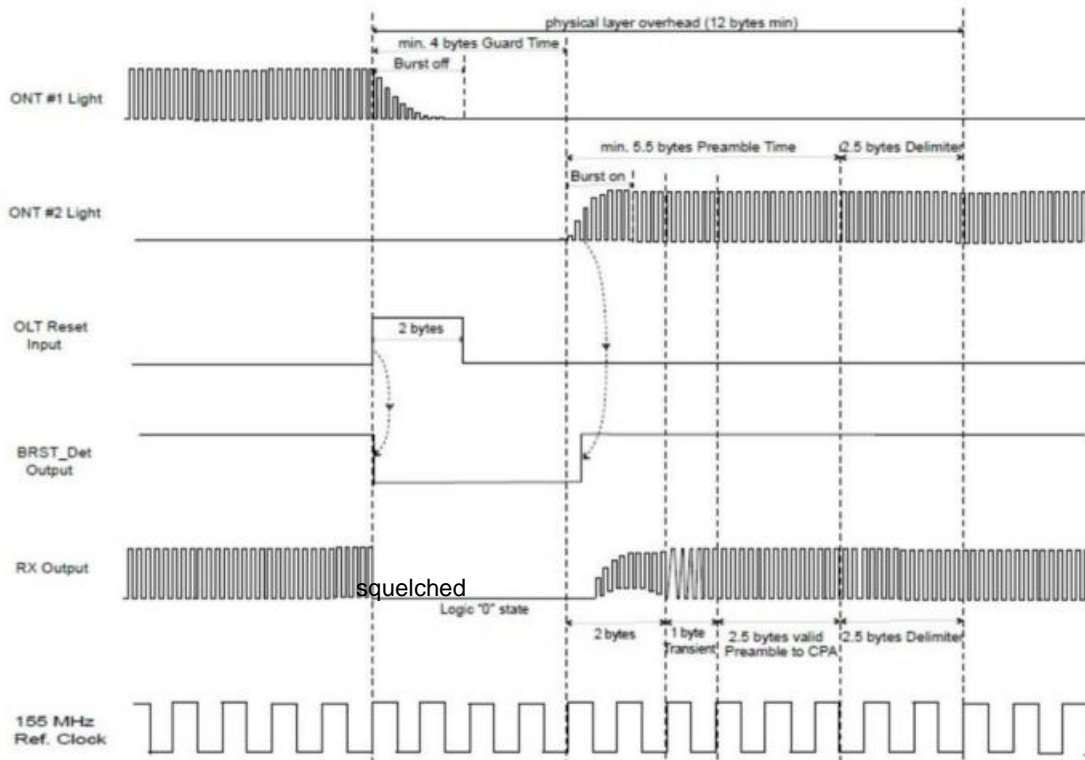

Figure1 Time parameter definition in GPON system

## Timing Of Digital RSSI

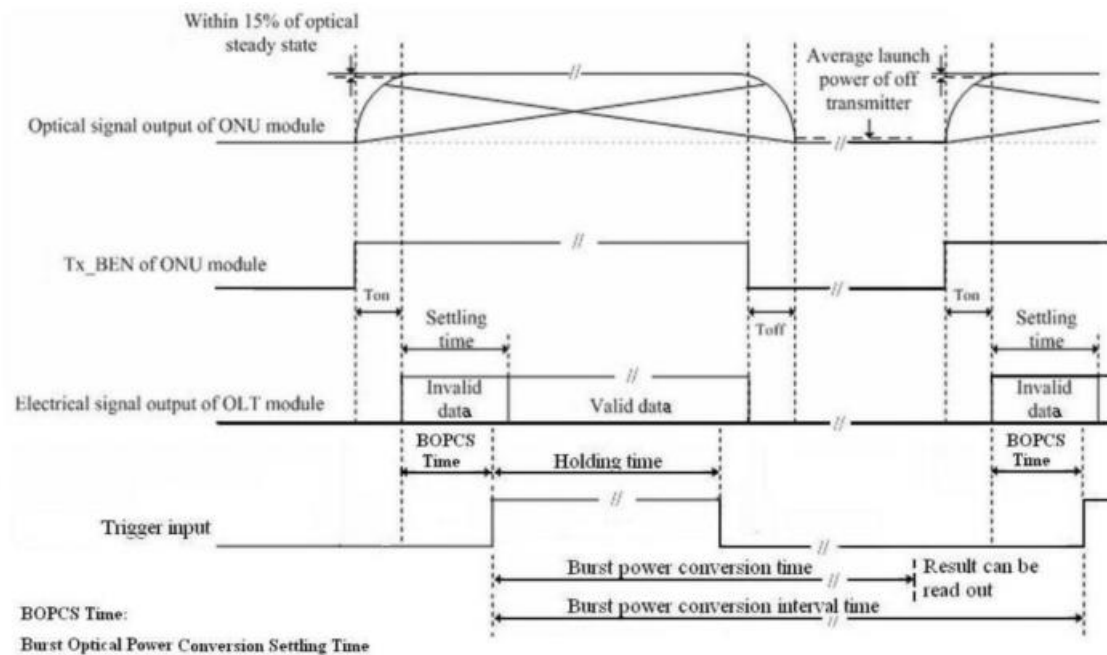

Figure2 Trigger sequence definition in GPON system

PARAMETER	SYMBOL	MIN	TYP	MAX	UNITS
Packet Length	-	600	-	-	ns
Trigger delay	BOPCS	100	-	-	ns
RSSI Trigger and Sample Time	Holding Time	400	-	-	ns
Internal delay	Conversion time	500	-	-	us

## COMPONENT INFORMATION

COMPONENT INFORMATION		
component description	P/N	Vendor
1490nm Laser Diode	HT2.5G1490D-C7V3A8	海信
TIA	MG3122	敏石
APD	XSJ-10-APD4-55-01	芯思杰
LDD	UX3320	优迅
LA	MG3150G	敏石
MCU	C8051F396-A-GM	Silicon Lab